

DRWG. NO:
0801092

FAIRPORT YACHTS, LTD.

SHEET:
1 OF 1

NOTES:
FABRICATE FROM 14 GAUGE (.075) TYPE 304 STAINLESS STEEL
CLEAN WELDS, BREAK ALL SHARP EDGES
POLISH TO HIGH GLOSS

REVISION TABLE			
REV.	DESCRIPTION	DATE	APPR. BY

1 EA. REQUIRED PER BOAT
ADDITIONAL 1 EA. REQUIRED PER BOAT
WITH OPTIONAL PEDISTAL GUARD

DRILL AND COUNTERSINK FOR #10 FLAT HEAD MACH. SCREW (2 PLACES)

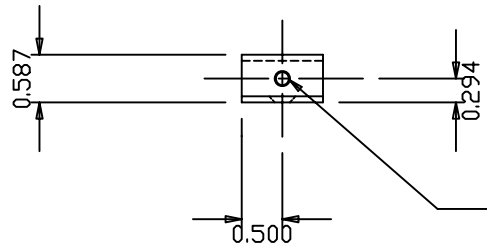
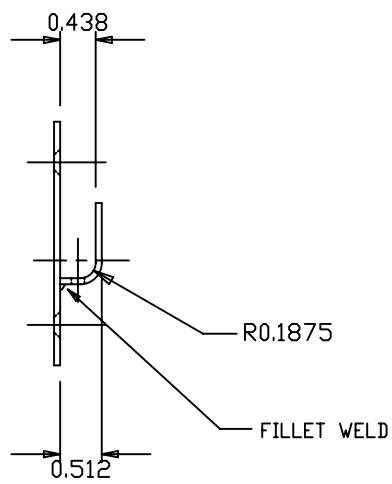
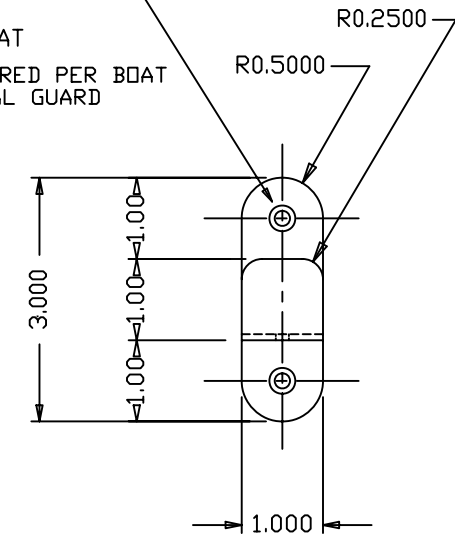

DRILL AND TAP FOR #10-32 MACH. SCREW

DRWG. DATE:
09/18/01
DRWN. BY:
R.LANNOCH

SCALE:
NONE
DRWG. LOCATION:
S:\PRODD-ENG\C&C99\DRAWINGS\0801092

APPROVED BY:
M.MITCHELL

DRWG. TITLE:
CATCH, TABLE SUPPORT C&C99